

Industrial Barrier Gate Operator
 IBG24DCW / IBG24DCG
 W=White; G=Dark Grey



Key Features

Battery Backup	2x 12V 7Ah batteries standard (up to 5 days). Upgradeable to 2x 12V 33Ah batteries (up to 23 days).
Remote Control Access	Security+ 2.0® 3-channel receiver will handle up to 64 remote controls (unlimited remotes with 811MX/813MX).
Fire Dept Compliant	Yes
Limit Settings	Electronic
Operating Time	6s open/close time. Adjustable in the menu interface.
Power	120V/230V AC single phase. Convert three phase power (208/240/480/575) to single phase 120V with accessory.
Accessory Power	24VDC, 1A
Operator Weight	159 lbs; includes bracket and 2x 12V 7Ah batteries.
Temperature Specification	Without Heater: -4°F (-20°C) to 140°F (60°C) With Optional Heater: -40°F (-40°C) to 140°F (60°C)
UL® Usage Classification	UL Certified: UL 325 and UL 991 – Class I, II, III, IV
Motor	24VDC brushless motor with soft start/stop.
Gear Reduction	303.5:1 Direct Drive
Operator Duty Rating	Continuous Duty
Programmable Relays	5 total. 1 on the main control board and 4 via auxiliary boards.
Display Interface	LCD color display with 4 button interface.

Specifications

Chassis/Frame	10-gauge aluminum, powder-coated for corrosion resistance.
Arms	Functional Length: 18', 24' can be cut down in the field,
LED Arms	No
Tower LED	Standard integrated red/green LED lights; programmable via operator display.
Internal Counterbalance	Adjustable internal counterbalance system (springs). No counterweights.
Arm Bracket Orientation	Pennant arm mounting to the bracket is required for this application.

Industrial Barrier Gate Operator
IBG24DCW / IBG24DCG
W=White; G=Dark Grey

Arm Strike Detection

Magnetic contact sensor will stop the arm motion when triggered and register a local error log event. When connected, a notification can be pushed via myQ.

Arm Wind Rating
Warranty

Up to 60 mph winds
2 years

Connectivity

Wi-Fi®

Wi-Fi, Cat 5/6 Ethernet to myQ Facility.

Wireless Pairing

Connect other LiftMaster TECHNA gate operators and cap equipment wirelessly over 900MHz.

Local and Remote Diagnostics

Local log of 50 events correlated to cycle number, unlimited if connected to myQ.

Track Cycle Counts

Vend, cycle, vehicle, and maintenance cycle counts visible via display screen.

Industrial Barrier Gate Operator
 IBG24DCW / IBG24DCG
 W=White; G=Dark Grey

Arm Selection

Straight Arms	Description	Operator Compatibility
IBGARM18	18' Functional Length Arm	IBG
IBGARM24	24' Functional Length Arm	IBG

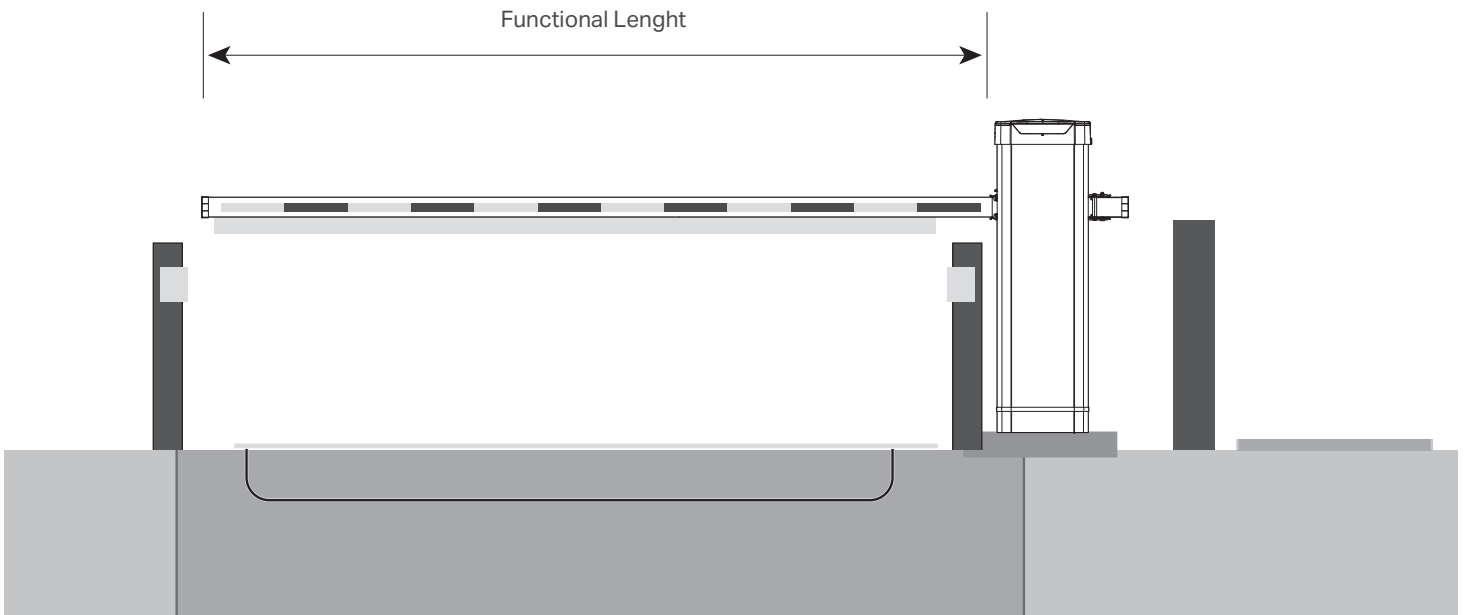

Industrial Barrier Gate Operator

IBG24DCW / IBG24DCG

W=White; G=Dark Grey

Dimensions

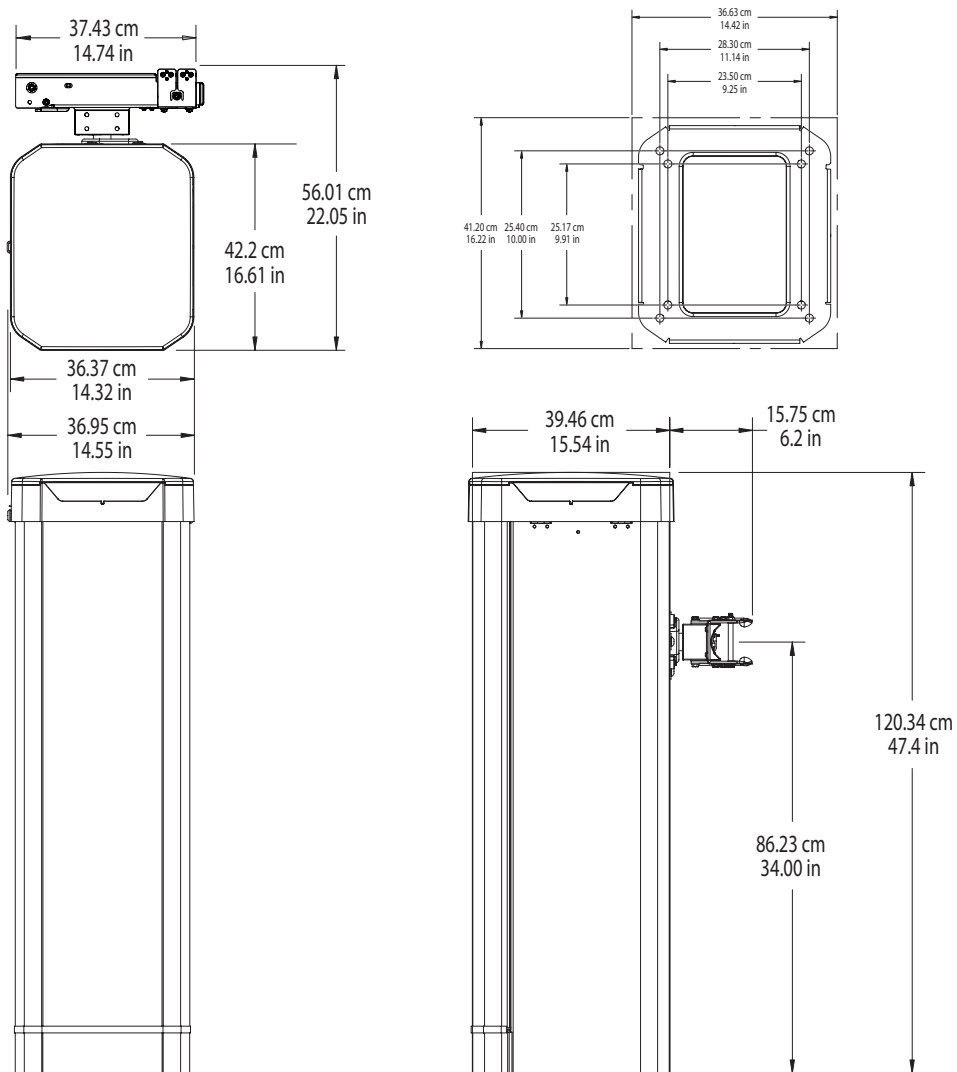

Smart. Simple. Built to Last.



Pro Partner Support (800) 528-2806

LiftMaster.com/TECHNA | LMCENDSUSTECHNAIBG 01/26

© 2026 Chamberlain Group LLC. All rights reserved.

LiftMaster, the LiftMaster logo, myQ, and the myQ logo are registered trademarks of Chamberlain Group LLC. UL® and the UL logo are trademarks of UL LLC. Wi-Fi® is a registered trademark of Wi-Fi Alliance.

LiftMaster | myQ.

COMMERCIAL SOLUTIONS